

SPECIFICATIONS

➤ **PROCESS TYPE:**
Dry Mix / Wet Mix

➤ **PERFORMANCE:**
Maximum volume outputs*

DRY/ 22000 lbs per hour (9979Kg)

WET/ 10 yards per hour
@ 2.5" slump (7.65CM/63.5mm)

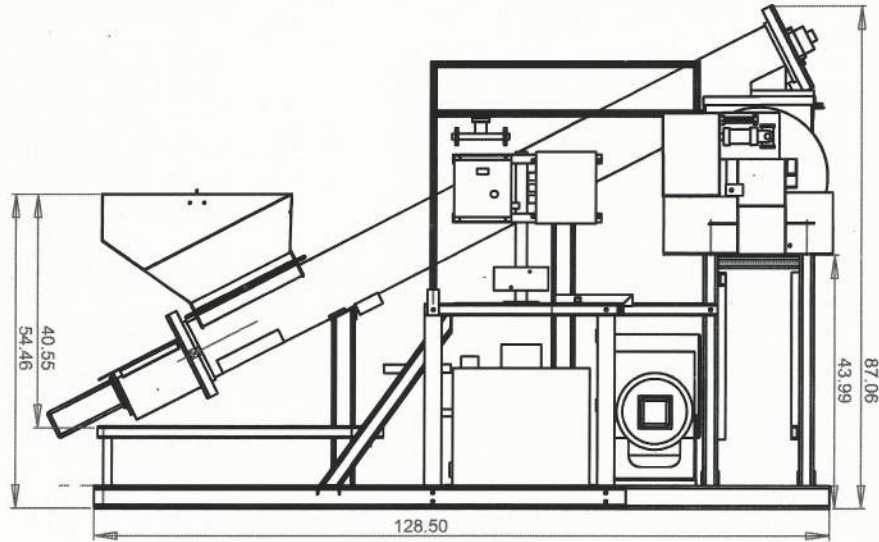

➤ **MATERIALS:**

Bag or tote bag premixed material
Maximum Aggregate size 3/4 inch (19mm)
Compatible with wire and fibreglass fibres

➤ **POWER:**
20HP (14.9Kw) 60Hz/ 3Ph/
230/460/600v Electric Motor
OR
29HP (21.6Kw) Diesel Engine

➤ **DIMENSIONS and WEIGHT:**

Length 134" (3403mm)
Width 91.25" (2318mm)
Height 87" (2210mm)
Weight 3500Lbs (1590Kg) (Approximate)

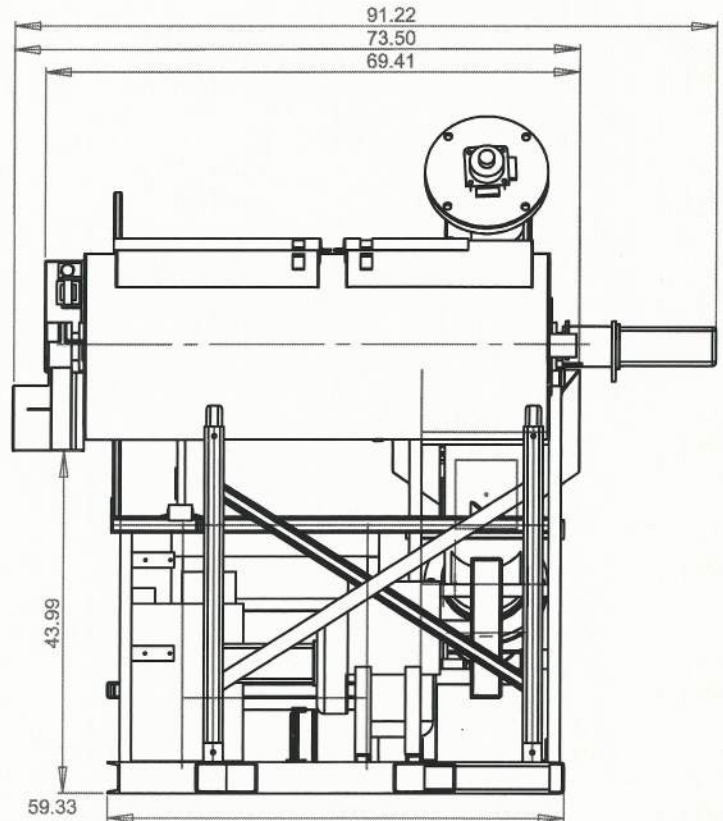

* Based on conveyor and mixer speed, material, water content and concrete mix design.
Specifications subject to change without prior notice. Weights vary with options selected.
Photos for illustrative purposes only. Refer to operations manuals for safe and proper operation.

Manufactured in North America

CANUSA
EQUIPMENT LTD